



Align VSI-8 Rear Mount

Instructions for Assembly

Making Workspace Work® is a trademark of Lista International Corporation.

Creation Date	Document Number	Rev	Description
Sep/24/10	AS66001	C	Align VSI-8 Rear Mtg

This manual is proprietary information of Lista International Corporation. Unauthorized reproduction of any portion of the manual is prohibited without consent of Lista International Corporation. The material in this manual is for informational purposes only. It is subject to change without notice. Lista International Corporation assumes no responsibility for any typographical errors contained in the manual.

© 2010 by Lista International Corporation, all rights reserved.
106 Lowland Street
Holliston, MA 01746-2094
E-mail: sales@listaintl.com

All rights reserved.

For questions or technical support, call 1-800-722-3020
ISO 9001 Certified

Align VSI-8 Rear Mount

Assemble the column mounting bracket to the “U” brackets loosely using the 5/16”-18 x 1 1/2” partially threaded hex bolts, lock washers and flat washers ensuring the longer leg of the “U” brackets are oriented as shown below. Loosely mount the column and plate to the column mounting brackets using the 5/16”-18 x 1 1/4” fully threaded hex bolts, flat washers, and lock nuts as shown. Slide the assemblies into the rear mount frame of the Align bench and position the columns on center according to the module size ordered. Install the modesty panel to ensure correct bay spacing. With this done secure the column mounting bracket and “U” brackets. Then push or rotate the top of the column towards the front of the bench and secure the column hardware.

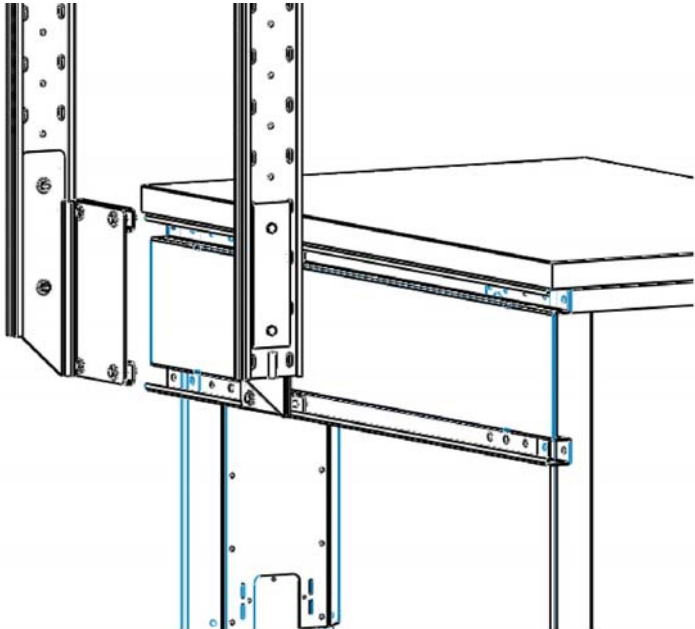
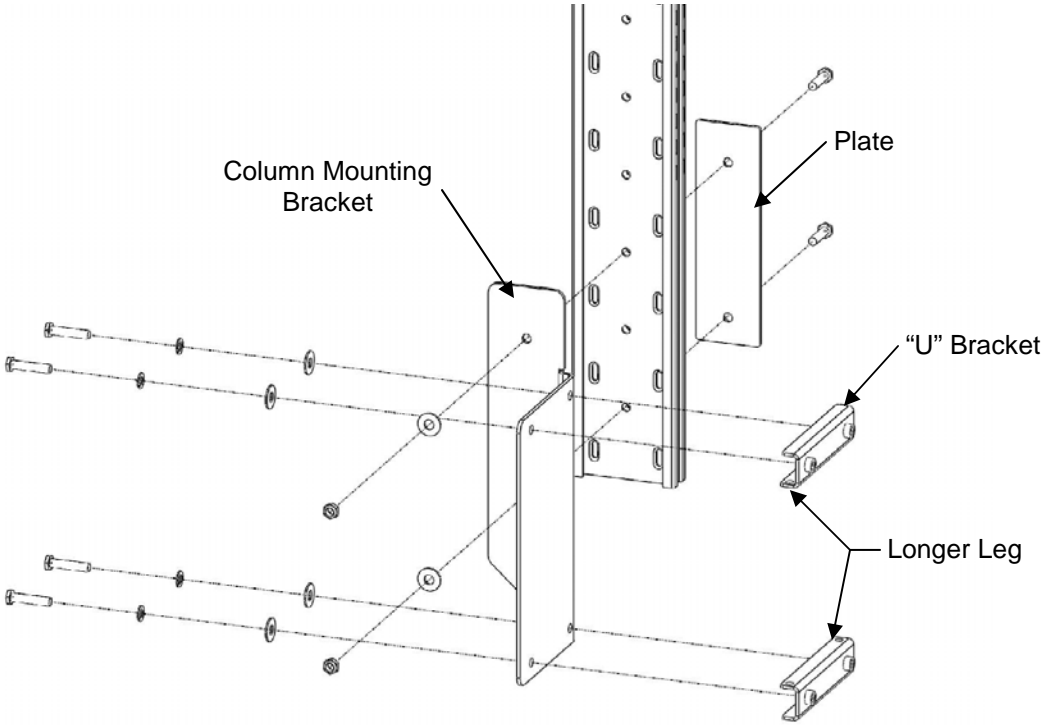

Document Number: AS70007

Print Date: September, 2010

This manual is proprietary information of Lista International Corporation. Unauthorized reproduction of any portion of this manual is prohibited without written consent of Lista International Corporation. The material in this manual is for informational purposes only. It is subject to change without notice. Lista International Corporation assumes no responsibility for any typographical errors contained in this manual.

©2010 by Lista International Corporation
106 Lowland Street
Holliston, MA 01746-2095

All rights reserved.

making workspace work®

Lista International Corporation

106 Lowland Street
Holliston, MA 01746 USA
Telephone: (800) 722-3020
Fax: (508) 626-0353
sales@listaintl.com
www.listaintl.com